

# 产品规格书

批准	审核	校核	编制
纪春华	/	朴致均	郑羿
2018.08.10	/	2018.08.10	2018.08.10

规格书更改履历:

序号	更改内容	履历号	更改时间	责任人
1	新规制定	000	2018.03.28	郑羿
2	增加封面	001	2018.07.24	郑羿
3	增加 MARK 丝印名	002	2018.08.10	郑羿
4	修改 VCEO 范围	003	2018.08.13	郑羿

## Descriptions

- General purpose application
- Switching application

## Features

- High voltage:  $V_{CE0}=65V$
- Complementary pair with KBC856

## Ordering Information

Type NO.	Marking	Package Code
KBC846	QA □ □.	SOT23
HKBC846	KN □ □.	SOT23
	① ② ③	

① Device Code ② HFE Rank ③ Year & Week Code • Dalian

## PIN Connection

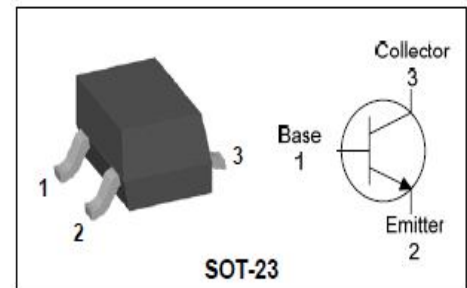

## Absolute maximum ratings

 $T_a=25^{\circ}C$ 

Characteristic	Symbol	Ratings	Unit
Collector-Base voltage	$V_{CBO}$	80	V
Collector-Emitter voltage	$V_{CEO}$	65	V
Emitter-base voltage	$V_{EBO}$	5	V
Collector current	$I_C$	100	mA
Collector dissipation	$P_C$	200	mW
Junction temperature	$T_j$	150	$^{\circ}C$
Storage temperature range	$T_{stg}$	-55~150	$^{\circ}C$

## Electrical Characteristics

 $T_a=25^{\circ}C$ 

Characteristic	Symbol	Test Condition	Min.	Typ.	Max.	Unit
Collector-Emitter breakdown voltage	$BV_{CEO}$	$I_C=1mA, I_B=0$	65	-	-	V
Base-Emitter turn on voltage	$V_{BE(ON)}$	$V_{CE}=5V, I_C=2mA$	550	-	700	mV
Base-Emitter saturation voltage	$V_{BE(sat)}$	$I_C=100mA, I_B=5mA$	-	900	-	mV
Collector-Emitter saturation voltage	$V_{CE(sat)}$	$I_C=100mA, I_B=5mA$	-	-	600	mV
Collector cut-off current	$I_{CBO}$	$V_{CB}=35V, I_E=0$	-	-	15	nA
DC current gain	$h_{FE}^*$	$V_{CE}=5V, I_C=2mA$	110	-	800	-
Transition frequency	$f_T$	$V_{CE}=5V, I_C=10mA$	-	150	-	MHz
Collector output capacitance	$C_{ob}$	$V_{CB}=10V, I_E=0, f=1MHz$	-	-	4.5	pF
Noise figure	NF	$V_{CE}=5V, I_C=200\mu A, f=1KHz, R_g=2K\Omega$	-	-	10	dB

\* : hFE rank / A : 110 ~ 220, B : 200 ~ 450, C : 420 ~ 800

Electrical Characteristic Curves

Fig. 1  $P_C - T_a$

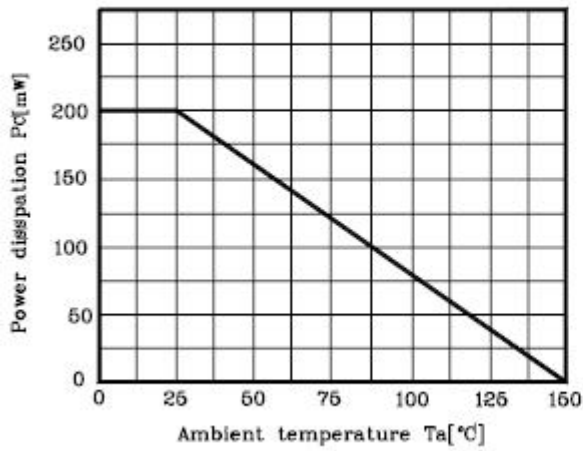

Fig. 2  $I_C - V_{BE}$

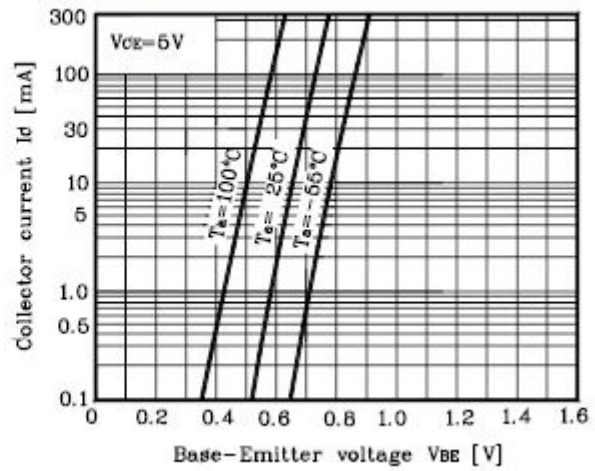

Fig. 3  $I_C - V_{CE}$

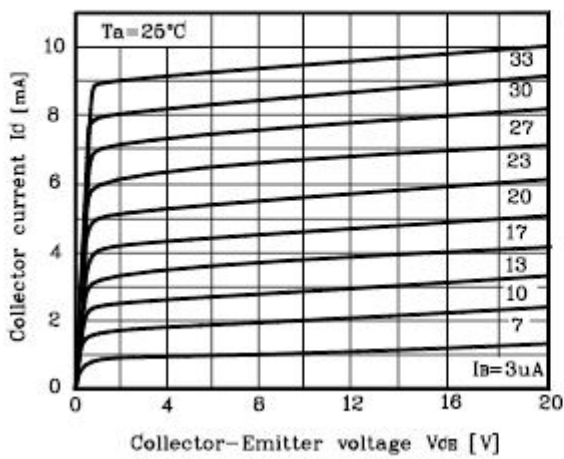

Fig. 4  $h_{FE} - I_C$

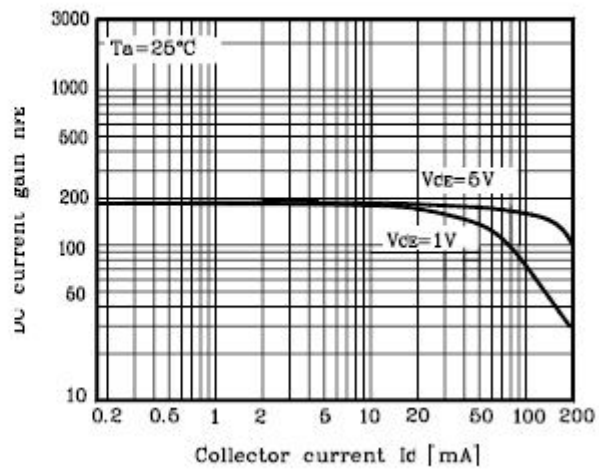
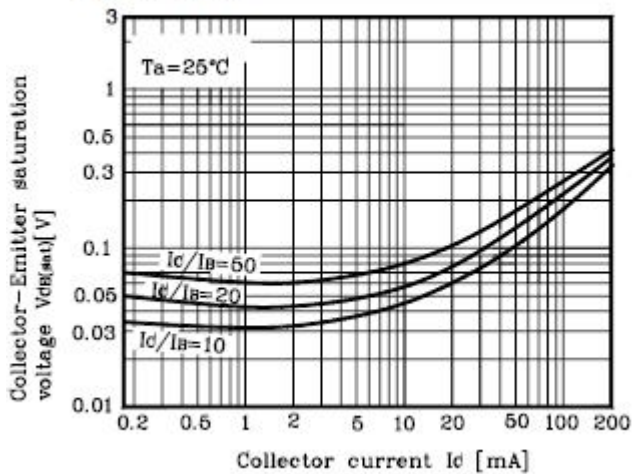
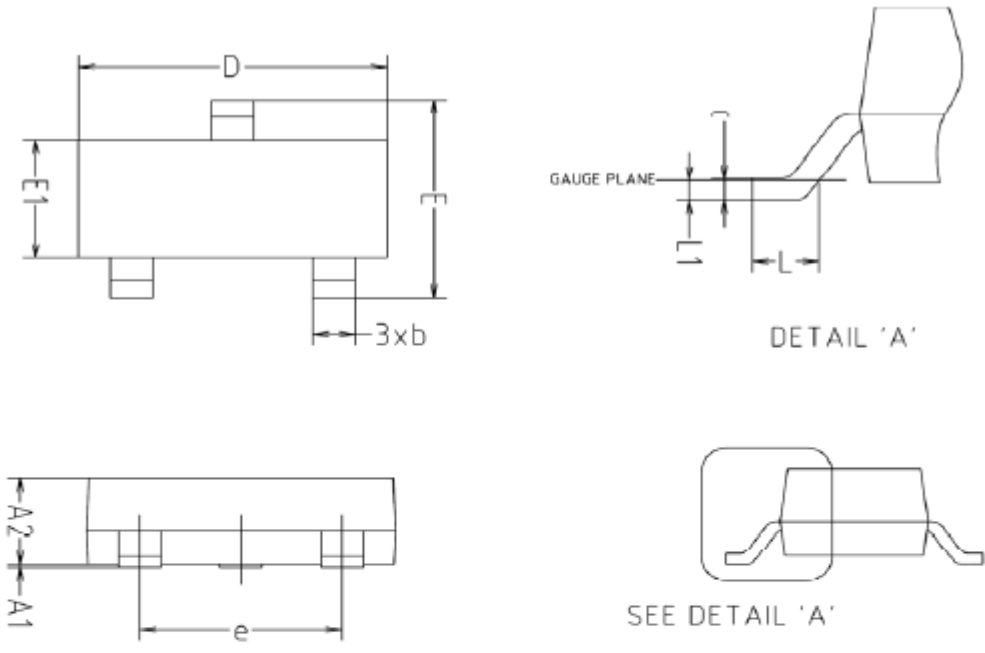

Fig. 5  $V_{CE(sat)} - I_C$



Outline Dimension



SYMBOL	MILLIMETERS			NOTE
	MINIMUM	NOMINAL	MAXIMUM	
A1	0.00	-	0.10	
A2	0.82	-	1.02	
b	0.39	0.42	0.45	
c	0.09	0.12	0.15	
D	2.80	2.90	3.00	
E	2.20	2.40	2.60	
E1	1.20	1.30	1.40	
e	1.90BSC			
L	0.20	-	-	
L1	0.12BSC			

※Recommend PCB solder land [Unit: mm]

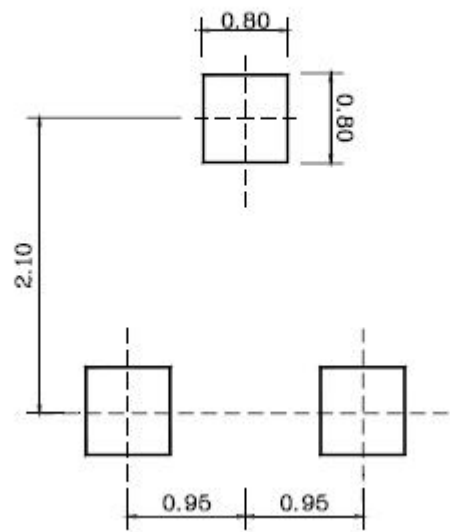

**The AUK Dalian Corp. products are intended for the use as components in general electronic equipment (Office and communication equipment, measuring equipment, home appliance, etc.).**

**Please make sure that you consult with us before you use these AUK Dalian Corp. products in equipments which require high quality and / or reliability, and in equipments which could have major impact to the welfare of human life(atomic energy control, airplane, spaceship, transportation, combustion control, all types of safety device, etc.). AUK Dalian Corp. cannot accept liability to any damage which may occur in case these AUK Dalian Corp. products were used in the mentioned equipments without prior consultation with AUK Dalian Corp..**

**Specifications mentioned in this publication are subject to change without notice.**